

NEW
640x512
@ 15 μ m

SILVER 660M

Large format infrared cameras for R&D and thermography applications

- Large focal plane array
- Uses fast high linearity ROIC
- Ultra high sensitivity typical 15 mK
- 3-5 μ m spectral range
- 120 Hz full frame max frame rate
- Up to 20 000 Hz with 16x4 pixel sub window
- Smart trigger and advanced capabilities
- Full radiometric capabilities
- Motorized filter wheel and focus control
- Plug & play interface with CAMLINK and USB2

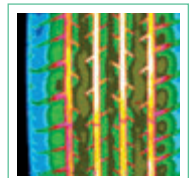
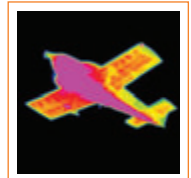
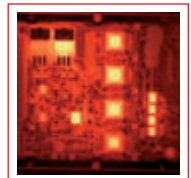

> The SILVER 660M is the latest large format IR cooled camera featuring high resolution and high sensitivity.

The SILVER 660M is specifically designed for the most demanding users of IR technology, who want to perform thermal imagery at high spatial resolution with the highest sensitivity and accuracy at an affordable cost.

Ultra high frame rate obtained from the latest ROIC technology - Our 640x512 pixels format InSb focal plane array delivers an outstanding 120 Hz frame rate while keeping extraordinary linearity and sensitivity figures. The use of our latest read out integrated circuit technology provides low noise and high pixel rate without compromising sensitivity.

Frame rate, sub arrays windowing mode and smart trigger and advanced capabilities - The frame rate is programmable from 1 Hz to 120 Hz in full frame format. Sub array windowing modes are user friendly and flexible. Integration time is adjustable in 1 μ s increments. The smart external triggering feature allows synchronization of the image capture to the most fleeting of events.

Plug & Play interfaces - The SILVER 660M is truly plug & play using either CAMLINK or USB2.0 interfaces to transmit both commands and full dynamic range digital video. Using the CAMLINK interface gives access to third party off the shelf frame grabber cards.

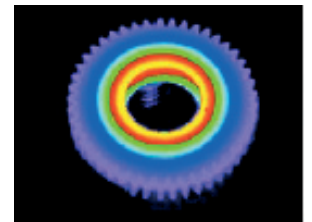
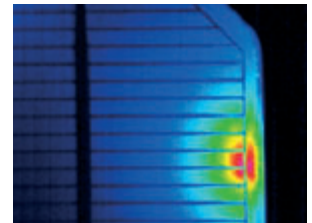

- 1 Heat dissipation by conduction only, no fan = no dust inside
- 2 Temperature sensors for precise radiometric measurements
- 3 Smart trigger input ultra low jitter
- 4 High quality S-Video
- 5 USB2 connection for commands
- 6 CAMLINK interface transfer digital video at the faster frame rate



- 7 High performance InSb FPA
- 8 Long life durability cooler >10 000 hours MTBF
- 9 Rugged cast aluminium housing
- 10 Removable filter wheel
- 11 Build in lens motorized auto-focus

> SILVER 660M and ALTAIR software provide outstanding recording capabilities and radiometric performances.

Plug & play interfaces

The SILVER 660M is fully compatible with ALTAIR software for digital image recording and radiometric measurement even at full frame rate. The CAMLINK output of the camera allows transference of images at 40 MHz pixel rate and full 14 bits dynamic range. Advanced image analysis features and functionalities dedicated to thermal measurements are standard.

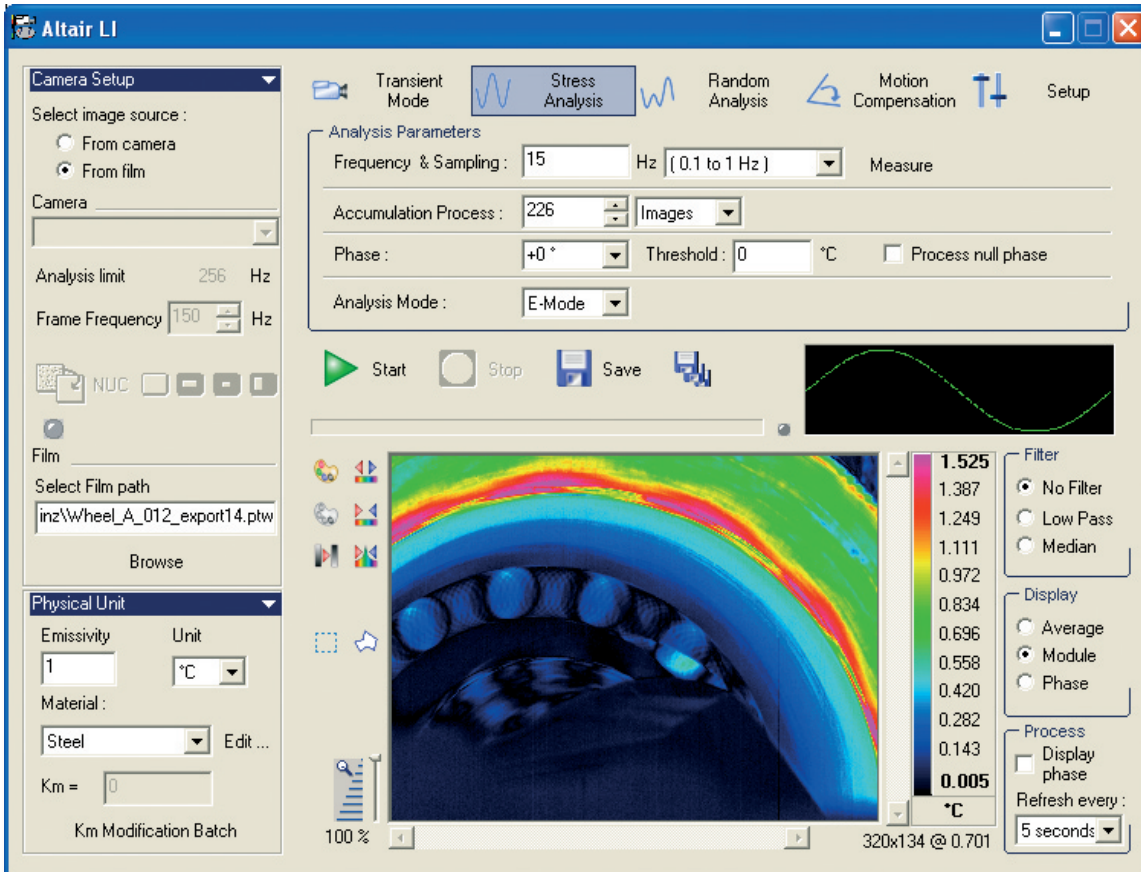
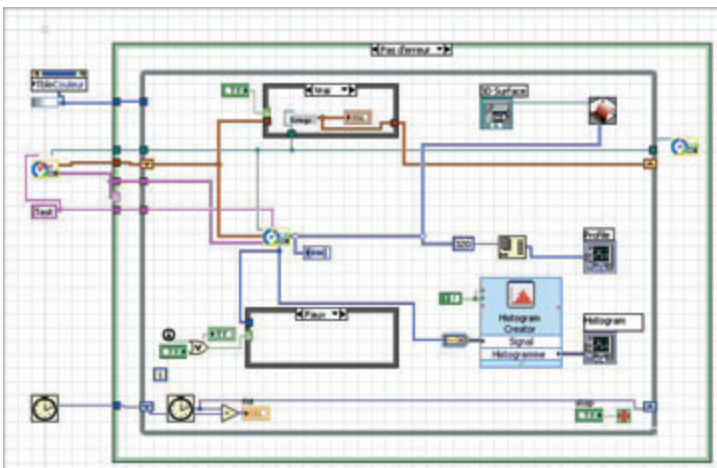
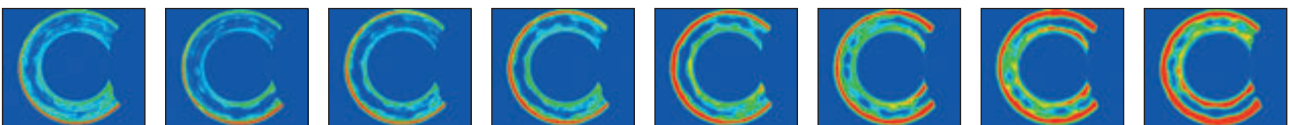

Image sequence of a brake disks study taken at 120 frames per seconds.



For users who want to interface the camera with their own experiments, we offer a complete Labview on C++ driver interface for controlling the camera features, acquiring and processing images.

> Silver 660M. Large format infrared cameras for R&D and thermography applications

Feature List for SILVER 450M

Sensor type	InSb
Waveband	3.7 - 5.1 μm
Pixel resolution	640 x 512
Pitch	15 μm
NETD	< 20 mK - Typical 15 mK
Cooler	Integral stirling cooler
Frame rate	Up to 120 Hz full frame
Sub array windowing	Random size arbitrary location (min 16x4)
Integration time	Variable from 10 μs to 5000 μs
Frame rate in subwindow mode	20 000 Hz with 16x4 pixel sub window
Lens	Built in motorized optical lens-25mm
Optical interface	Bayonet
Field of view	20° x 15°
Filter wheel	Removable filter carrier wheel – 4 slots available
Analogue video	S-Video
Digital Video	USB2 and CAMLINK – 14bits digital data
Trigger input	Smart trigger capabilities-Pre & post trigger features-TTL input
Trigger jitter	< 300 ns (ITR Mode)
Temperature calibration range	-20 °C to +150 °C / +100 °C to 1500 °C
Temperature measurement accuracy	+/- 1°C for temperature < 100°C +/- 1 % above

Physical specifications

Size (LxWxH)	310 x 135 x 165 mm
Weight	3.6 kg
Base mounting	Standard 1/4"
Operational temperature	-15 °C to +50 °C
Shock	Operational 25 G, IEC 68-2-29
Vibration	Operational 2 G, IEC 68-2-26
Input voltage	+12 VDC
Power consumption	30 Watt

Optional lenses - Bayonet mount

Microscope lens G1 :X1 - 12.5 μm resolution
Close up lens : 50 μm resolution
12 mm FOV 38°
50 mm FOV 11°
200 mm FOV 2,5°



PRELIMINARY SPECIFICATIONS



Cedip Infrared Systems

General Head Office
19 bd Georges Bidault - F/77183 Croissy Beaubourg
France
Tel: +33 (0)1 60 37 01 00
sales@cedip-infrared.com

Cedip Infrared Systems Ltd.

DBH House - Carlton Square
Nottingham - NG4 3BP
United Kingdom
Tel: +44 0 1159408625
uksales@cedip-infrared.com

Cedip Infrared Systems GmbH

Frankfurter Ring 193a
80807 München
Germany
Tel: +49 89 321 9770 - 0
info@cedip-infrared.de

Cedip Infrared Systems AB

Tullgatan 8
64032 Malmköping
Sweden
Tel: +46 157 246 60
info@cedip-infrared.com

www.cedip-infrared.com